

BUBBLE-JET ACTUATED CELL SORTING

H. Hoefemann^{1*}, N. Bakhtina^{1,2}, S. Wadle^{1,2}, V. Kondrashov^{1,2}, N. Wangler² and R. Zengerle^{1,2,3}

¹Institut für Mikro- und Informationstechnik der Hahn-Schickard-Gesellschaft für angewandte Forschung e.V. (HSG-IMIT), GERMANY, ²Department of Microsystems Engineering - IMTEK, University of Freiburg, GERMANY, ³BIOSS Centre for Biological Signalling Studies, University of Freiburg, GERMANY

ABSTRACT

We present cell sorting based on Bubble-Jet actuation. $35 \times 35 \mu\text{m}^2$ heaters for bubble generation are fabricated on transparent Borofloat® wafer substrates and embedded into microfluidic channels in PDMS. The chips are assembled onto customized printed circuit boards (PCBs) in standard microscopy slide format of $76 \times 26 \text{mm}^2$. **Hydrodynamically focused** L929 mouse fibroblast cells are flowing with velocities in the order of **$500 \mu\text{m/s}$ inside a channel ($120 \times 45 \mu\text{m}^2$)**. Cells of interest are **selectively deflected about $60 \mu\text{m}$** from their original streamline by **Bubble-Jet actuation** to flow into a collector outlet.

KEYWORDS: bubble jet, deflection, cell sorting, microscopy, soft lithography

INTRODUCTION

To enable single-cell analysis, cells of interest must be continuously selected and sorted out of a sample. So far a wide range of different effects and actuation principals for on-chip cell sorting have been investigated to integrate single-cell analysis in a microfluidic system [1]. Bubble-Jet technology, known from inkjet printers and dispensing applications in the picolitre range [2], offers an actuation principle predestinated for miniaturization and a high integration density.

FUNCTIONAL PRINCIPLE

Cells are hydrodynamically focused to follow a virtual streamline into a waste outlet prior to deflection. The lateral position of the focused cells in the channel is defined by the incoming flow rates of the side channels controlled by high precision syringe pumps (Fig. 1, Fig. 2). The Bubble-Jet heater is positioned in a chamber adjacent to the main channel and connected to it via a nozzle. By applying series of electrical pulses to the heater an expanding vapor bubble is created. This leads to fluid displacement from the chamber through the nozzle into the main channel. A selected cell in front of the nozzle is thus deflected to a new streamline leading towards the collector outlet.

The cell sorting chip is a combination of a borosilicate chip with microheaters and a PDMS chip with microchannels. This hybrid approach offers high flexibility and versatility in the chip layout. Due to the small heater size the integration density is increased in comparison to the usage of off-chip valves [3] or piezo elements [4]. In contrast to an opaque silicon based system [5] the chip is transparent and thus allows for an easy observation of experiments without a complex setup for optical deflection [6].

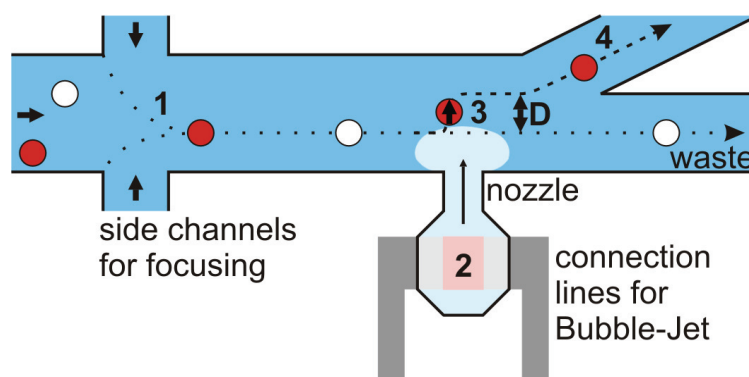

Figure 1: Operating principle of Bubble-Jet actuated cell sorting. Cells are hydrodynamically focused (1). The Bubble-Jet heater (2) creates an expanding vapor bubble displacing fluid in the heater chamber which is channelized through a nozzle and deflects a cell (3) with a certain lateral deflection (D) towards a separate outlet (4).

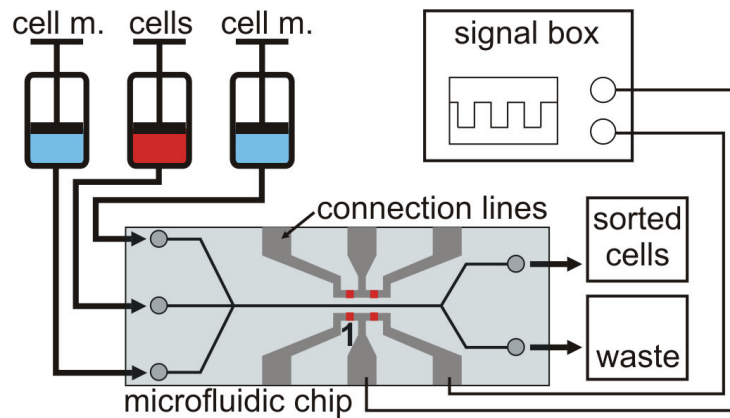

Figure 2: Experimental setup. The chip is mounted onto an inverse microscope (not shown) for cell observation. Cells and cell medium are injected into the chip with high precision syringe pumps (neMESYS, Cetoni GmbH, Germany). The Bubble-Jet heaters (1) are actuated by a signal box (Pico-Injector Signal Box, Biofluidix GmbH, Germany).

FABRICATION

The symmetrically arranged four Bubble-Jet heaters ($35 \times 35 \mu\text{m}^2$) per chip have been made of 100 nm titanium and connected via 600 nm aluminium connection lines on Borofloat®33 substrates. The photolithography process is described in [2]. Fluidic structures with a main channel $120 \mu\text{m}$ wide and $45 \mu\text{m}$ deep have been manufactured with the common PDMS replica molding process and bonded by oxygen plasma treatment to the heater chip. The electrical connection is established via a customized PCB (Fig. 3).

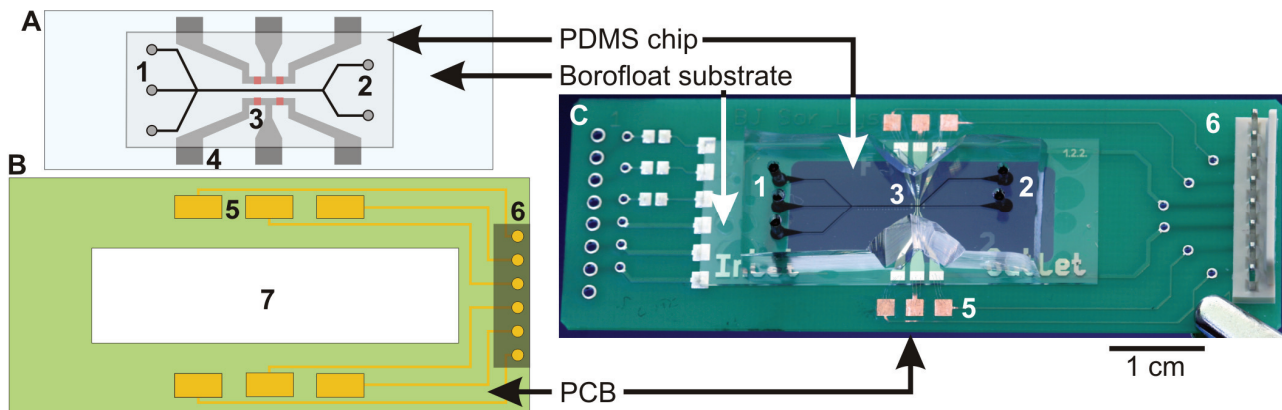

Figure 3: Chip fabrication. A: The structured PDMS chip with fluidic inlets (1) and outlets (2) is plasma bonded to the Pyrex substrate with heater elements, connection lines (3) and bond pads (4). B shows the PCB with bond pads (5), electrical connector (6) and cut out (7) for microscopy. C shows the completely assembled chip.

EXPERIMENTAL RESULTS AND DISCUSSION

In order to establish vapor bubbles living long enough to displace enough liquid for cell deflection multi-pulse patterns of 50 pulses (5.5 V , $2.5 \mu\text{s}$ single pulse width) and different time intervals between the pulses have been investigated (Fig. 4). High lateral cell deflection distances up to $60 \mu\text{m}$ have been achieved this way. Due to the manual procedure in the early stage of this project the flow velocity of the cells has been reduced to about $500 \mu\text{m/s}$. Successful sorting of polystyrene beads ($\varnothing 26 \mu\text{m}$) and L929 mouse fibroblasts ($\varnothing 15\text{-}25 \mu\text{m}$) has been demonstrated within an overall actuation time period of 5 ms (Fig. 5) which would theoretically enable to sort in the order of 100 – 200 cells/s.

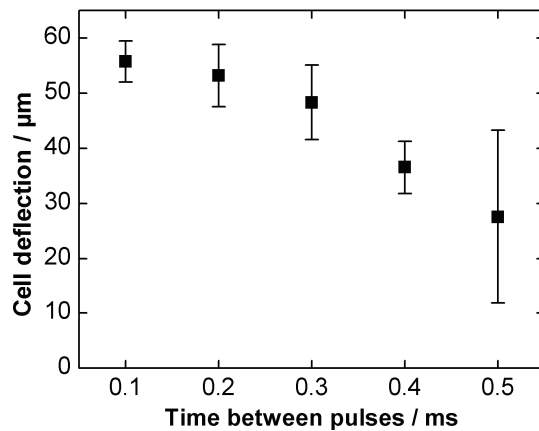

Figure 4: Deflection. The diagram shows the lateral deflection of cells from their original streamlines. With growing time between pulses heat loss increases thus reducing Bubble-Jet effectiveness and achievable cell deflection.

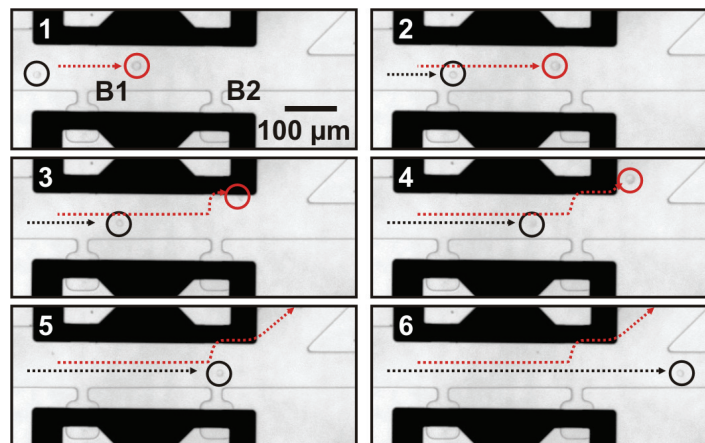

Figure 5: Cell sorting. The photograph series shows the sorting area of the chip with two cells passing the nozzles of two Bubble-Jets (1, B1 & B2). The black structures are the connection lines. The upper cell (red) is deflected (3) and enters the sorting channel (4).

CONCLUSION

We successfully demonstrated that Bubble-Jet technology enables fast and selective cell sorting on a transparent chip. Future work will focus on the integration of automated image analysis for cell detection to increase efficiency, throughput and reproducibility. With increasing cell velocity we expect to accomplish cell deflection with shorter pulse patterns. Sorting frequencies of up to 1000 – 2000 cells / s should be feasible.

ACKNOWLEDGEMENTS

We thank the Cleanroom Service Center at IMTEK for the good cooperation. Financial support from the BIOSS Centre for Biological Signalling Studies is gratefully acknowledged.

REFERENCES

- [1] H. Andersson et al., *Sensors and Actuators B*, **92**, 2003, 315-325
- [2] N. Wangler et al., *Proc. MicroTAS 2010*, Groningen, Netherlands, October 2010, 1205-1207
- [3] A. Wolff et al., *Lab Chip*, **3**, 2003, 22-27
- [4] S. H. Cho et al., *Lab Chip*, **10**, 2010, 1567-1573
- [5] C. C. Chen et al., *Sensors and Actuators B*, **117**, 2006, 523-529
- [6] M. M. Wang et al., *nature biotechnology*, **23**, 2005, 83-87

CONTACT

*H. Hoefemann, tel: +49-7721-943257; henning.hoefemann@hsg-imit.de